

CO-AX Carbon Monoxide Sensor – EN 50379 Compliant for Stack Gases

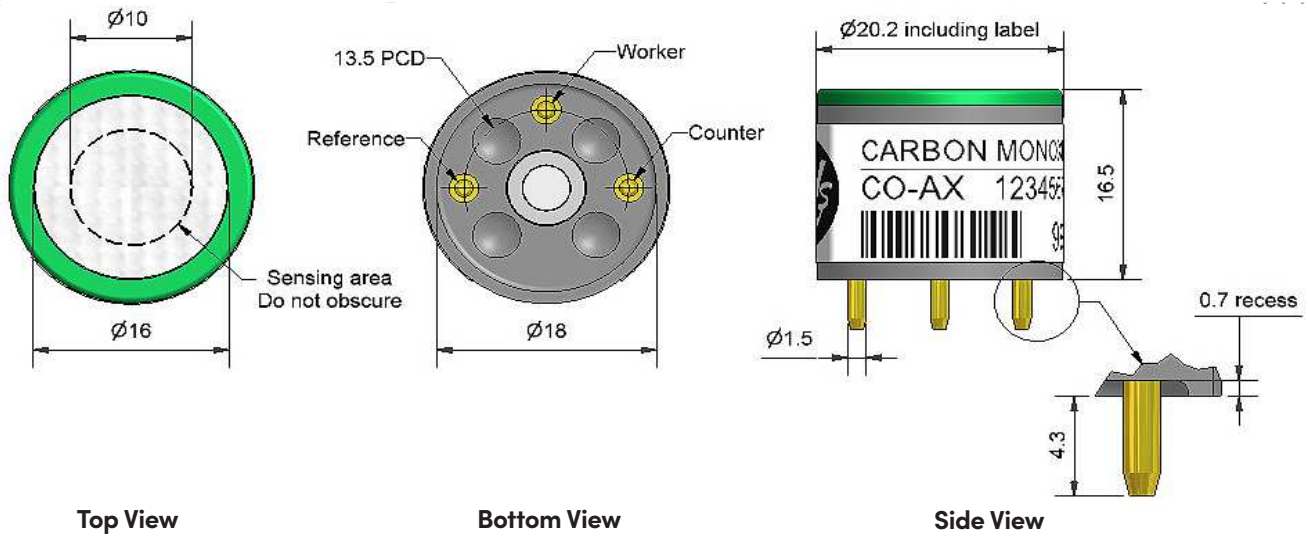

Dimensions are in millimetres (± 0.1 mm).

Performance	Sensitivity	nA/ppm in 400ppm CO	55 to 100	
	Response time	t90 (s) from zero to 400ppm CO	< 30	
	Zero current	ppm equivalent in zero air	< ± 3	
	Resolution	RMS noise (ppm equivalent)	< 0.5	
	Range	ppm CO limit of performance warranty	2,000	
	Linearity	ppm error at full scale, linear at zero and 800ppm CO	< ± 40	
	Overgas limit	maximum ppm for stable response to gas pulse	4,000	
	Lifetime	Zero drift	ppm equivalent change/year in lab air	< 0.2
Sensitivity drift		% change/year in lab air, monthly test	< 6	
Operating life		months until 80% original signal (24-month warranted)	> 24	
Environmental	Sensitivity @ -20°C	(% output @ -20°C/output @ 20°C) @ 400ppm CO	55 to 75	
	Sensitivity @ 0°C	(% output @ 0°C/output @ 20°C) @ 400ppm CO	75 to 90	
	Sensitivity @ 40°C	(% output @ 40°C/output @ 20°C) @ 400ppm CO	106 to 120	
	Zero @ -20°C	ppm equivalent change from 20°C	< 0 to 4	
	Zero @ 0°C	ppm equivalent change from 20°C	< 0 to 3	
	Zero @ 50°C	ppm equivalent change from 20°C	< 0 to -6	
Cross Sensitivity	Filter capacity	ppm-hrs	H ₂ S 250,000	
	Filter capacity	ppm-hrs	NO ₂ 500,000	
	Filter capacity	ppm-hrs	NO 20,000	
	Filter capacity	ppm-hrs	SO ₂ 250,000	
	H ₂ sensitivity	% measured gas @ 900ppm	H ₂ in 900ppm CO @ 10°C	< 2
	H ₂ sensitivity	% measured gas @ 900ppm	H ₂ in 900ppm CO @ 20°C	< 4
	H ₂ sensitivity	% measured gas @ 900ppm	H ₂ in 900ppm CO @ 30°C	< 6
	NO ₂ sensitivity	% measured gas @ 10ppm	NO ₂	< -1
	Cl ₂ sensitivity	% measured gas @ 10ppm	Cl ₂	< 0.1
	NO sensitivity	% measured gas @ 500ppm	NO	< -2
	SO ₂ sensitivity	% measured gas @ 20ppm	SO ₂	< 0.1
	C ₂ H ₄ sensitivity	% measured gas @ 400ppm	C ₂ H ₄	< 5
NH ₃ sensitivity	% measured gas @ 20ppm	NH ₃	< 0.1	
Key Specifications	Temperature range	°C	-30 to 50	
	Pressure range	kPa	80 to 120	
	Humidity range	% rh continuous	15 to 90	
	Storage period	months @ 0 to 20°C (stored in sealed pot)	6	
	Load resistor	Ω (recommended)	10 to 47	
	Weight	g	< 6	

Figure 1 CO Sensitivity Temperature Dependence

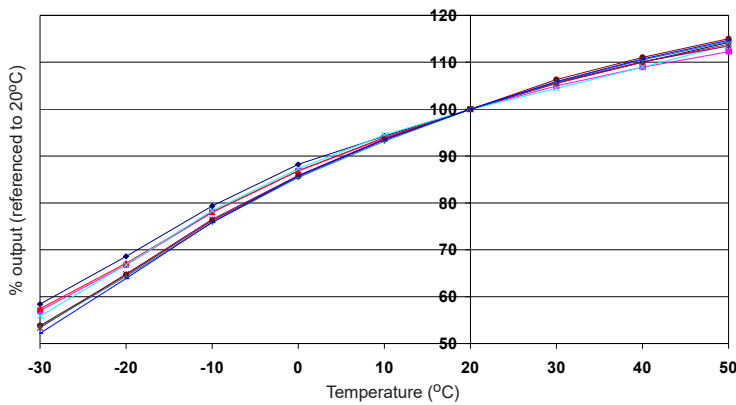

Figure 1 shows the variation in sensitivity caused by changes in temperature.

This data is taken from a typical batch of sensors.

Figure 2 Hydrogen Sensitivity Temperature Dependence

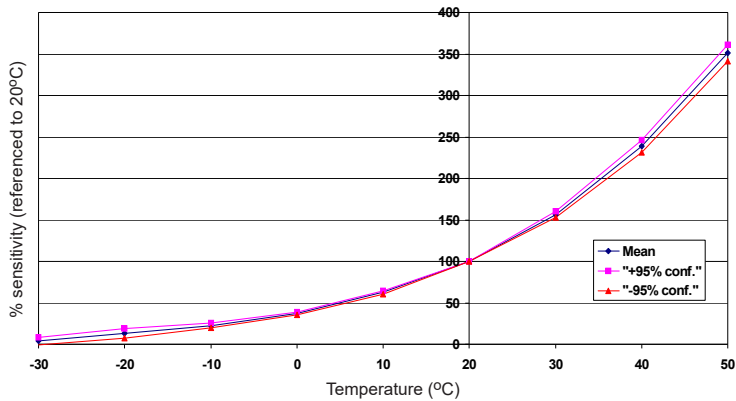

Figure 2 shows the strong temperature dependence of the CO-AX to hydrogen. Since hydrogen sensitivity is less than 4% at 20°C, hydrogen interference can practically be ignored at low temperatures.

However, at 50°C hydrogen interference is 14%.

This data is taken from a typical batch of sensors.

The mean and $\pm 95\%$ confidence intervals are shown.

Figure 3 Hydrogen Cross Sensitivity at 30°C

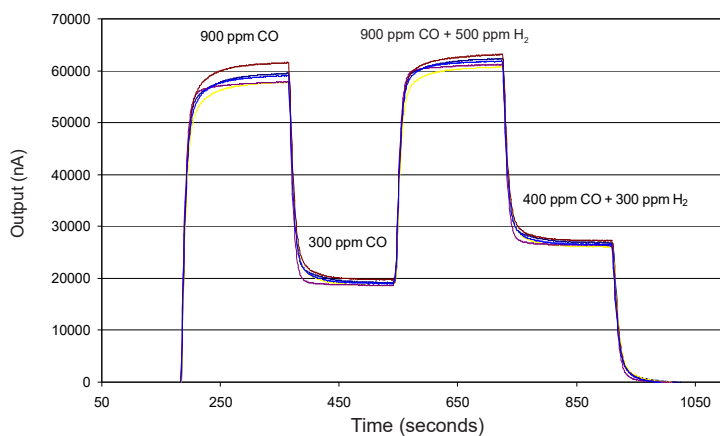

Figure 3 shows hydrogen sensitivity for a typical batch of eight CO-AX sensors at 30°C following EN50379. All sensors show less than 5% cross sensitivity when 500ppm hydrogen is added to 950ppm carbon monoxide. t_{90} is less than 45 seconds.

Important. The CO-AX must be operated with a 0 Volt bias between Reference & Working electrodes. Failure to comply with this requirement will result in a loss of its low Hydrogen cross sensitivity performance.

At the end of the product's life, do not dispose of any electronic sensor, component or instrument in the domestic waste, but contact the instrument manufacturer, Alphasense or its distributor for disposal instructions. NOTE: all sensors are tested at ambient environmental conditions unless otherwise stated. As applications of use are outside our control, the information provided is given without legal responsibility. Customers should test under their own conditions, to ensure that the sensors are suitable for their own requirements.

In the interest of continued product improvement, we reserve the right to change design features and specifications without prior notification. The data contained in this document is for guidance only. Alphasense Ltd accepts no liability for any consequential losses, injury or damage resulting from the use of this document or the information contained within. (©ALPHASENSE LTD) Doc. Ref. CO-AX/SEP22